

PARTS LIST						
ITEM	QTY	PART NO.	PART DESCRIPTION	LENGTH	UNIT WT.	NET WT.
1	10	X-TOAB-BPL	TIE-OFF ANCHOR BRACKET BENT PLATE	2 in	0.83	8.32
2	10	G5802	5/8" x 2" HDG HEX BOLT GR5		0.27	2.70
3	10	G58FW	5/8" HDG USS FLATWASHER	1/8 in	0.07	0.70
4	10	G58LW	5/8" HDG LOCKWASHER		0.03	0.26
5	10	G58NUT	5/8" HDG HEAVY 2H HEX NUT		0.13	1.30
6	10	SHK14	1/4" SCREW PIN SHACKLE		0.10	1.05
					TOTAL WT. #	14.33

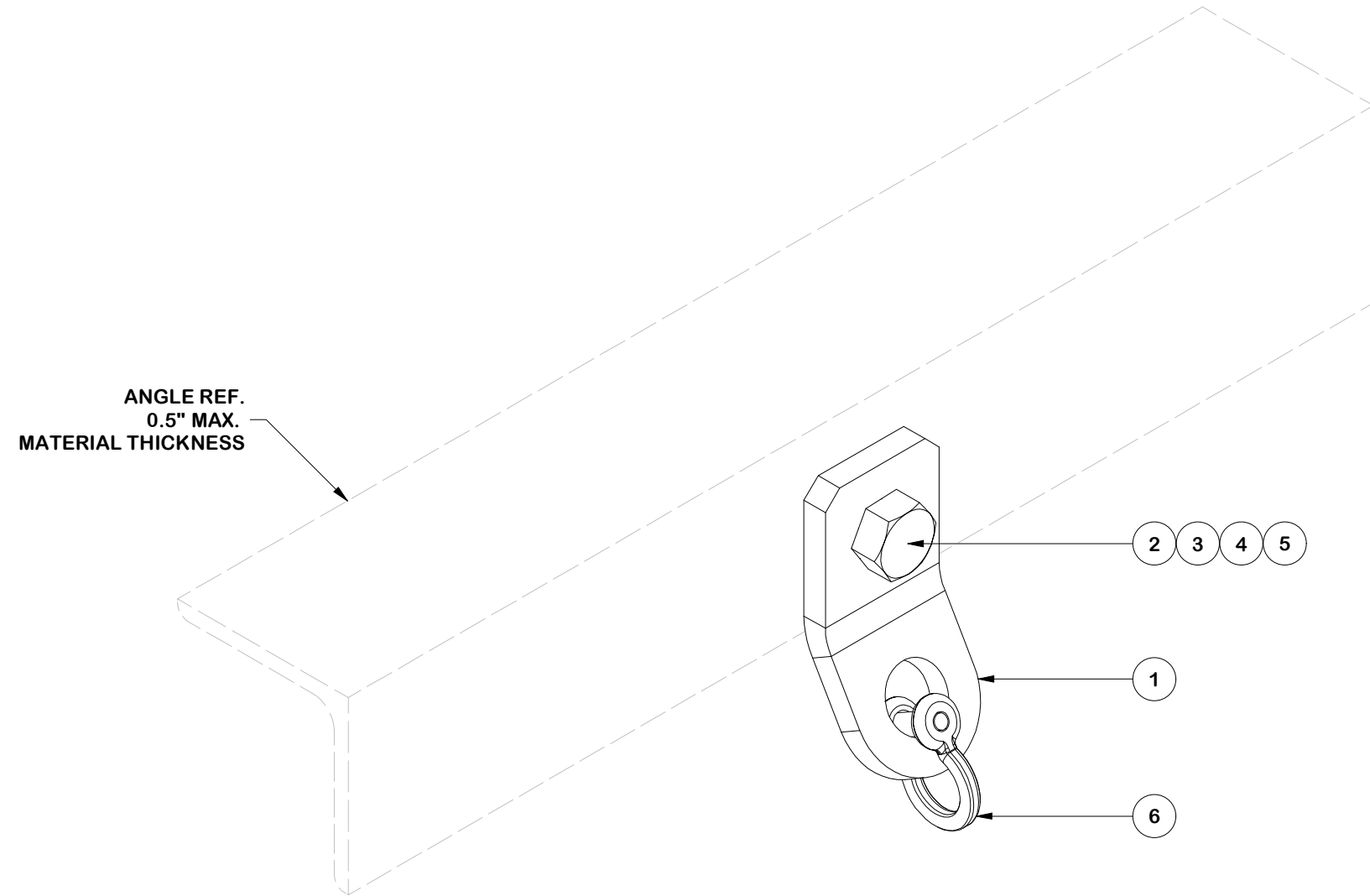

X 10

FINISH:
HOT DIP GALVANIZED.

TOLERANCE NOTES
 TOLERANCES ON DIMENSIONS, UNLESS OTHERWISE NOTED ARE:
 SAWED, SHEARED AND GAS CUT EDGES ($\pm 0.030"$)
 DRILLED AND GAS CUT HOLES ($\pm 0.030"$) - NO CONING OF HOLES
 LASER CUT EDGES AND HOLES ($\pm 0.010"$) - NO CONING OF HOLES
 BENDS AND ANGLES ARE $\pm 1/2$ DEGREE
 ALL OTHER MACHINING ($\pm 0.030"$)
 ALL OTHER ASSEMBLY ($\pm 0.060"$)

PATENT INFORMATION: WWW.SITEPRO1.COM/PATENTS

PROPRIETARY NOTE:
 THE DATA AND TECHNIQUES CONTAINED IN THIS DRAWING ARE PROPRIETARY INFORMATION OF VALMONT INDUSTRIES AND CONSIDERED A TRADE SECRET. ANY USE OR DISCLOSURE WITHOUT THE CONSENT OF VALMONT INDUSTRIES IS STRICTLY PROHIBITED.

DESCRIPTION
**CABLE ATTACHMENT POINT
 W/ 1/4" SHACKLES
 (10 PACK)**

CPD NO. NCS	DRAWN BY CSL 10/16/2025	ENG. APPROVAL 11/10/2025
CLASS 87	SUB 02	DRAWING USAGE CUSTOMER
CHECKED BY KMS 11/10/2025		

SITE PRO 1
 A valmont COMPANY

Engineering Support Team:
 sp1engineering@valmont.com

PART NO. CAP14-10K	PAGE 1 OF 1
DWG. NO. CAP14-10K	